

Qoltec[®]



USER MANUAL

Inverter Solar water heating converter

Model : 53867

INTRODUCTION

Thank you for your trust and choosing our Solar BOOST MPPT solar inverter. We are convinced that the product will meet your expectations. This manual will help you familiarize yourself with the device and facilitate the configuration, and so it will help with any problems that may arise during the use of the device. In case of any problems, please read this manual before contacting customer service.

ABOUT THIS MANUAL

This manual describes the assembly, installation, operation and troubleshooting of this device. Before installing and operating the device, please read this manual carefully. This manual provides detailed information on the installation and operation of the MPPT solar electric heating controller.

SAFETY INSTRUCTIONS

The device installer must have electrical qualifications and be familiar with the principles of solar system design and wiring.

Before beginning installation, carefully read the instructions and precautions in this manual.

- Do not disassemble the converter for self-repair purposes.
- Before installing or moving the device, make sure all power supplies are disconnected.
- During operation, the device produces heat that can cause burns. Install the inverter in a place that is not easily accessible.
- Use insulated tools when connecting the power cord.
- Do not wear jewelry during installation.
- Make sure the power cord connection is solid to prevent the connector from overheating and causing a fire due to a loose wire.
- Use proper wiring and switches.

The following symbols described below appear in this manual to indicate potentially dangerous situations or to highlight important safety points:

WARNING!

This sign indicates a risk of danger when performing specific activities.

ATTENTION!

This sign indicates key operational steps that must be performed to ensure safe operation of the controller.

ABOUT THE PRODUCT

ECO Solar Boost solar water heater inverter with MPPT technology is designed to deliver electricity generated by solar panels to the electric heater with maximum efficiency thanks to MPPT technology. It converts direct current from photovoltaic panels into square wave alternating current, which can be directly connected to traditional water heaters. Equipped with an intelligent control function, enabling intelligent switching between solar and grid energy.

The description of the functions of individual parts of the device is shown in the figure below.

Illustration 1

1— Input terminal PV

Connect to positive (+) PV wire

- Connect to negative (-) PV wire

2— Temperature Detection Terminal

3— Output interfaces AC OUTPUT

L - Connect to the phase wire (L) of the water appliance

N - Connect to the neutral wire (N) of the water appliance

PE - Protective earthing conductor for water device

4— Input interfaces AC input (AC INPUT)

L - Connect to the phase wire (L) of the power grid

N - Connect to the neutral wire (N) of the power grid

PE - Connect to the mains grounding wire

5— Operator panel with LCD display and LED diodes

LCD Display: Shows the working status of the controller

Green LED: indicates normal status

Red LED: indicates emergency condition

ESC Button: Cancel / Back

UP button: Switch to previous mode

DOWN button: Switch to next mode

ENTER button: Confirm

6- WIFI

TECHNICAL SPECIFICATION

Rated power	4000W	3000W
Scope of application	The MPPT water heating controller is only suitable for heating heating elements by solar energy and the load of the controller can be used to connect equipment or AC heaters, heating power in the range of 420V/4000 watts.	
IP	IP65	
PV Characteristics		
Maximum PV input power	4000W	3000W
Solar Power Input Current	≤ 20A	≤ 15A
Solar Input Voltage Range	160VDC ~ 350VDC	110VDC ~ 300VDC
MPPT operating voltage range	120VDC ~ 340VDC	90VDC ~ 290VDC
MPPT efficiency	>99%	
PV Input Current Range	≤ 20A	≤ 15A
AC		

AC heating rated power power (bypass)	4000W	4000W
Nominal AC voltage	230VAC	
AC operating voltage range	180Vac ~ 260Vac	
Nominal current AC	≤20A	
Load requirements		
Load	The load should not be greater than 230V/4000W, and the resistance value cannot be less than 130h.	

SYSTEM OPERATION DIAGRAM

Illustration 2

SYSTEM WIRING DIAGRAM

Illustration 3

DEVICE INSTALLATION PROCESS

The installation environment is crucial to the performance and service life of the product. It is recommended that the inverter be installed in a dry environment, protected from water. It is best to ensure sufficient ventilation around the product and adequate air flow.

Warning :Never install the device in a closed box! This device cannot be used in parallel!

Attention :Risk of equipment damage!

If the product is installed in a box, make sure there is sufficient ventilation inside and outside the box. A closed environment will cause excessive heat and shorten its service life.

Please read all installation instructions carefully before installation and follow the requirements strictly. Improper handling may cause damage to the product and affect its normal use.

Set of tools necessary for installation:

- Wire stripper

- Cable cutter
- Phillips screwdriver
- Crimping machine
- Pneumatic drill
- Spirit level
- Hacksaw (for cutting pipes with protective conductors)
- Nails for the wall

SELECTION OF PIPE DIAMETER

Selecting the correct wire gauge is essential for proper operation of the inverter. To ensure optimum performance, ensure that the voltage drop on the cable from the inverter to the solar panel, from the inverter to the heater, and from the inverter to the water dispenser is less than 2% of the system voltage.

Based on the calculated voltage drop and wire lengths, select the appropriate wire diameter according to the following table of minimum wire diameter requirements at an ambient temperature of 45 degrees Celsius:

	Maximum current	Type of cable	Recommended wire diameter	Minimum required wire diameter
Between the converter and the photovoltaic panel	20A	Copper	6.0mm ²	4.0mm ²
Between the converter and the load	20A	Copper	6.0mm ²	4.0mm ²
Between Controller and AC Input	20A	Copper	6.0mm ²	4.0mm ²

Remember that the right choice of cable will ensure long-term and trouble-free operation of the system.

HEATER SELECTION

Output interface: The heating load power cannot exceed 230V/4000W, and the resistance value cannot be less than 13 ohms.

WALL MOUNTING

1. Choose the right set of mounting holes: Find the mounting holes that best fit your chosen wall location.
2. Fixing the device :Mount the device vertically on the wall using expansion screws (plugs). Make sure the inverter is fixed firmly to prevent it from falling.

Illustration 4

Attention :Make sure the area is dry, well-ventilated and can support the weight of the device.

Make sure the device is mounted vertically to the mounting surface. If the installation angle deviates from the vertical by more than 45 degrees, it may cause poor ventilation of the product, which may affect its performance.

CONNECTING THE POWER CORD

Warning: Risk of electric shock!

The maximum open circuit voltage of the solar panel array should not exceed the maximum of 420VDC specified by the inverter. Before installation, make sure the solar panel and cable are disconnected.

Steps to connect wires:

1. Turn off all switches connected to the controller:
2. Make sure all switches are in the OFF position.

Attention : There is no built-in off switch in the device.

Attention! The positive and negative poles of the photovoltaic panel cannot be reversed!

Attention! Make sure the grounding is connected correctly!

Attention! If you connect a heating load exceeding the rated power, the controller may be damaged!

CONNECTING THE SOLAR PANEL WIRES

1. Connect the positive (+) wire from the solar panel to the PV+ terminal on the controller. Connect the negative (-) wire from the solar panel to the PV- terminal on the controller.
2. Connect the LOAD wire to the OUTPUT terminal of the controller. Select the load with appropriate power: The load power should not exceed 230V / 4000W, and the resistance value should not be less than 13 ohms.

Warning : The positive and negative poles of the solar panel cannot be reversed!

Connect:

Load L wire to OUTPUT L

Load N wire to OUTPUT N

Load PE wire to OUTPUT PE

Note! The controller is designed exclusively for heating resistive components powered by solar energy. Only resistive heating devices with a power of up to 230 V / 4000 W can be connected to the output, such as:

AC water heaters, heating cables, heating rods, PTC heaters.

Capacitive or inductive loads may damage the controller.

3. Connecting the AC input. Connect the AC network to the AC IN input of the controller:

AC Mains L Wire to AC IN L

AC Network N Wire to AC IN N

AC network PE wire to AC IN PE

CONNECTING THE AC POWER

1. Connect the AC mains line to the AC IN terminal on the inverter.
2. Connect the AC mains L wire to AC IN L.
3. Connect the AC mains N wire to AC IN N.
4. Connect the AC mains PE wire to AC IN PE.

Warning : Make sure the grounding is connected properly!

Attention : Before starting any wiring work, make sure that the inverter is disconnected from all power sources to avoid the risk of electric shock and damage to the device.

POWER ON

Attention : Pay attention to the terminal markings! Connecting photovoltaics to the AC IN or AC OUT terminal, connecting AC IN to a photovoltaic terminal or connecting AC IN to AC OUT will cause irreversible damage to the product.

Warning : Make sure the polarity is correct! If the positive and negative poles of the solar cell array are connected in reverse, the controller will not work properly.

Warning : Before turning on the power, make sure the grounding is connected correctly. Improper grounding will affect the leakage current protection function and may cause danger to the user!

Power on procedure

1. Confirm the polarity of the solar cell array: Make sure the positive (+) and negative (-) wires are connected correctly.
2. Check the condition of the grounding wire of the mains plug: Make sure that the grounding wire is in good condition.
3. Turn on the PV input breaker: Close the PV input breaker. If the voltage from the solar panel is suitable, the controller will start to use solar energy for heating.
4. Turn on the AC input breaker: Close the AC input breaker. If the voltage from the solar panel is not available, the controller will switch to AC IN and AC OUT power.

Attention : Following the above steps is crucial to ensure safe and proper operation of the inverter!!!

POWER TURN OFF

Warning : Pay attention to the order in which you turn off the power!

To safely turn off the power, follow these steps:

1. Disconnect the AC power source: Make sure the product is disconnected from the mains. Turn off the AC input breaker.

2. Disconnect the solar panel: Make sure the product is disconnected from the solar panels. Turn off the PV input switch.
3. Check Connections: Make sure both the AC power and the solar panel connections are completely disconnected from the inverter.
4. Removing Other Wires: Once you have made sure the product is completely disconnected from the AC power and solar panels, you can safely remove the remaining wires.

Attention : The correct sequence for turning off the power is crucial to ensure user safety and protect the product from damage.

PRODUCT SERVICE

Solar energy is the priority power source, and when solar energy is insufficient, the inverter will automatically switch to AC power.

Maximum Power Point Tracking (MPPT) technology

Maximum Power Point Tracking (MPPT) technology can detect the power generated by the solar panel in real time and track the maximum power generated by the solar panel to ensure that the solar cell array can operate at the current maximum power point. This process is automatically performed by the DSP (Digital Signal Processor) through a series of calculations.

Setting the maximum water temperature

1. On the operation panel, press the "up" key (up arrow).
2. The PV (solar water heating) temperature setting will be displayed.
3. Press the "enter" key (OK).
4. The maximum water temperature setting number will begin flashing.
5. Use the "up" and "down" keys to select the maximum PV temperature (you can choose between 55°C and 80°C).
6. Press the "enter" key again to complete the setting (the number will stop flashing), or press the "esc" key to cancel the setting.
7. When the PV is heated, the water temperature reaches the maximum temperature set for the PV and the PV stops heating. When the water temperature drops 3°C below the maximum temperature set for the PV, the PV stops heating.

Setting the maximum water temperature from the AC

1. On the operation panel, press the “up” key (up arrow).
2. The AC temperature setting will be displayed.
3. Press the “enter” key.
4. The maximum water temperature setting number will begin flashing.
5. Use the “up” and “down” keys to select the maximum AC temperature (you can choose between 30°C and 80°C).
6. Press the “enter” key again to complete the setting (the number will stop flashing), or press the “esc” key to cancel the setting.
7. When the AC is heated, the water temperature reaches the maximum temperature set for the AC and the AC stops heating. When the water temperature drops 3°C below the maximum temperature set for the AC, the AC stops heating.

MANUALLY FORCING THE SWITCH TO HEATING FROM THE AC NETWORK

When you need to force the switch from PV heating to AC grid heating, press and hold the button for 3 seconds.

If the AC network is working properly, the controller will force a switch to heating from the AC network.

Pressing the button again for 3 seconds will cause the controller to return to PV heating.

LCD DISPLAY

Illustration 5

The solar inverter is equipped with an advanced LCD display, which provides users with full control and transparency of the system operation. The intuitive display menu makes it easy to configure and adjust the inverter settings to the user's individual needs. The display shows current operating parameters, which allows for ongoing monitoring of the system's performance. Users can quickly check the current operating status of the inverter, including the operating mode (MPPT, BYPASS) and information about any errors or alarms.

Troubleshooting:

1. There is no LED indicator and the controller appears to have no electrical connection and does not turn on.

Use a multimeter to measure the voltage across the terminals of the solar panel connected to the controller. The voltage across these terminals must be above 160 V DC for the controller to operate.

If the voltage across the terminal ends of the photovoltaic panel is between 160V and 350V DC and the LED display still does not light up, please contact your local distributor.

Use a multimeter to measure the voltage between the L and N terminals of the AC socket and check the AC voltage range. The voltage must be above 180 VAC.

If the voltage between the LN terminals of the AC outlet is between 180V and 260V AC, check whether the AC plug is properly inserted and securely connected.

If the LED display still does not turn on, please contact your local distributor.

If the voltage at both ends of the controller's PV array wiring terminals is not measured, check whether the PV cable is in good condition and whether there is a fuse or circuit breaker in the circuit.

If there is no voltage at the AC outlet, verify that the AC power is working properly.

2. Red LED indicates error

Solution: Check if the controller has entered protection mode (code 4.5) or a fault condition (code 4.6).

If none of these protections have been activated, please contact your local distributor.

DISPLAY TIME SETTING

Illustration 6

On the control panel, press the ENTER button, select the time to modify, press the up/down buttons to change the value.

Press the ESC button, the number will stop flashing – the setting will be saved.

HEATING WITH TIME FUNCTION

Illustration 7

On the control panel, press the ENTER button, select the time to modify, press the up/down buttons to change the value.

Press the ESC button, the number will stop flashing – the setting will be saved.

Here the time heating function applies to heating from the power grid (AC).

It is possible to set two independent heating time intervals: time1 and time2.

SETTING THE HEATING MODE

Illustration 8

1. Photovoltaic (PV) heating has top priority.

When the voltage from the PV system is within the operating range of the controller, solar energy automatically powers the heating – it is not controlled by heating mode.

2. Time heating mode (from AC network):

Press and hold the button for 3 seconds to select time heating mode.

The appropriate mode icon will appear on the screen.

In time heating mode, when the set time comes: if the water temperature has not reached the set maximum AC heating temperature and the AC network is working properly, the controller will forcefully switch to AC network heating until the water temperature reaches the set value. Once the temperature is reached, the heating will stop. The above cycle will repeat every day.

3. Manual heating mode:

Press and hold the button for 3 seconds to select manual heating mode.

The corresponding mode icon will appear on the screen. In this mode, if the water temperature has not reached the maximum set AC temperature and the AC network is available, the controller will force switch to AC network heating.

Once the set temperature is reached, the AC heating will be turned off and the mode icon will disappear.

and the controller will switch back to PV heating.

WI-FI MODULE QUICK INSTALLATION GUIDE

Note: Only applies to the model with a built-in Wi-Fi module

Illustration 9

Please refer to the user manual for detailed parameters.

Installation steps

Connect the antenna to the Wi-Fi module body.

Illustration 10

PROTECTIVE FUNCTIONS

1. Solar panel power too high

The maximum output current of the controller is limited by the rated value. When the power of the solar panels connected to the controller exceeds the rated maximum value, the maximum output power of the device will be limited to the rated value. In this case, the inverter may not operate at the point of maximum power of the solar panels. The efficiency of the solar panels will be reduced.

2. Shortening the solar panel input line

When the solar panel input line is short-circuited, it is equivalent to no solar energy supply. Once the short-circuit is removed, the inverter will automatically resume normal operation.

3. Overheating protection:

If the ventilation around the controller is insufficient, the controller case temperature may be too high, exceeding the normal operating temperature range. In this case, the product will gradually reduce the photovoltaic output until the output stops. When the case temperature drops below the protective temperature, the controller will automatically restore the output.

ALARMS

1. High AC Input Voltage Alarm

Condition: If the AC input voltage exceeds 260VAC.

Indicator: The Fault indicator will light up.

Reaction: AC output will be cut off.

Recovery: When the voltage drops below 260VAC, the fault indicator will turn off and the controller will resume normal operation.

2. PV Input High Voltage Alarm

Condition: If the open circuit voltage of the solar cells connected to the controller exceeds the maximum input voltage specified by the device.

Risk: The product may stop working or become damaged.

Prevention: Make sure the open circuit voltage of the solar cells is below the maximum value specified by the controller to avoid damage.

Attention :These alarms are designed to protect the controller from operating outside safe voltage ranges, preventing damage and ensuring reliable operation.

REMOTE MONITORING AND CONTROL VIA SMART SWHS APPLICATION

Thanks to the Smart SWHS mobile application, users can remotely monitor and manage the device's operation, monitor water temperature, change settings and check system performance, which allows for optimizing its operation depending on current needs and easily adjusting parameters such as water temperature control (from 30°C to 80°C).

The QR code to download the application is in the attachment

Illustration 11

INSPECTION AND MAINTENANCE

To extend the life of your appliance, perform the following inspections twice a year.

1. System control

Check: Whether the controller is properly attached and whether the surrounding area is clean enough.

Ventilation: Make sure there is good ventilation around the controller and clean the surface of the controller from dust and dirt.

Power cord: Check whether the outdoor power cord is damaged due to aging, friction, insects or small animals. Check the insulation. If the cord is damaged, replace it in time.

Loose wires: Check if the external power cable is loose and tighten the loose wires.

LED Indicators: Check that the LED indicators are consistent with the operation of the device. If any faults or erroneous indications are observed, take corrective action immediately.

Grounding: Check that all grounding wires in the system are properly grounded.

2. Controller Wiring Cover Inspection

Attention :Danger of electric shock!

Before removing the wiring cover, make sure that all power sources connected to the controller are disconnected. If the power has not been disconnected, do not open the controller wiring cover. Open the controller wiring cover only 5 minutes after disconnecting the power.

Check: Whether the power cord in the junction box is damaged due to aging, friction, insects or small animals. If there is any damage, repair or replace it in time.

Loose wires: Check if the power wire at the junction box is loose and tighten any loose wires.

PROBLEM SOLVING

1. No LED indicator, controller seems to have no electrical connection and does not turn on.

Solution:

- a) Use a multimeter to measure the voltage across the controller's solar panel terminals. The voltage across the solar panel terminals must be above 160 VDC for the controller to operate. If the voltage across the controller's solar panel terminals is between DC 160V and 350V and the LED indicator does not light up, please contact your installer.
- b) Use a multimeter to measure the voltage between the AC LN socket and the AC voltage range. The voltage must be above AC 180V. If the voltage between the AC LN socket is between AC 180V and 260V, check if the AC plug is properly inserted or connected securely. If the LED indicator does not light up, contact your installer.

- c) If voltage is not measured at both ends of the controller PV panel wiring terminals, check if the PV cable is in good condition and if there is a fuse or circuit breaker in the circuit. If there is no voltage at the AC outlet, check if the AC power is normal.

2. Red alarm light is on

Solution:

- a) Check whether the controller has triggered the protection state described in § or the fault state described in §.

WARRANTY SERVICE REGULATIONS AND REPAIR PROCESS

1. Warranty service regulations

Within two years from the date of manufacture, any failures related to the operation of the product that are not caused by human error may be covered by warranty service.

2. Warranty exceptions

The following situations are not covered by warranty service:

- Damage caused by human action such as accidents, neglect, improper installation or misuse.
- Damage caused by voltage, power or load current of solar cells exceeding nominal values.
- Controller damage caused by selecting heaters with excessive specifications.
- Unauthorized modifications or repairs to the product.
- Damage incurred during transport.
- Damage caused by natural disasters such as lightning and extreme weather conditions.
- Damage caused by factors such as fires and floods.

Attachment 1

1

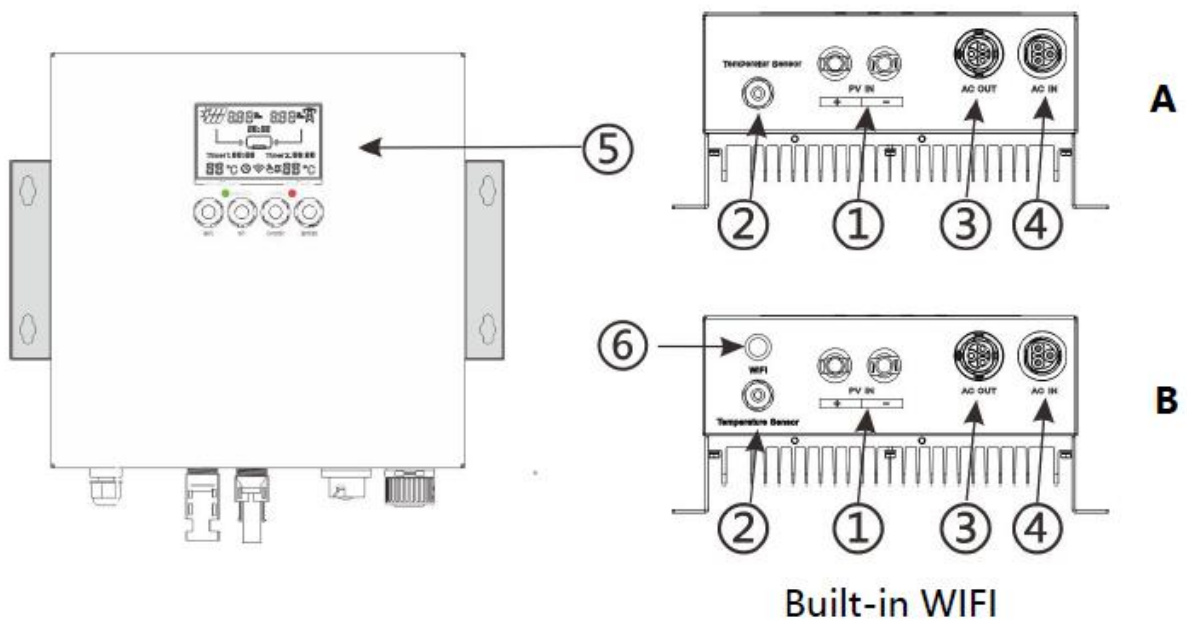

2

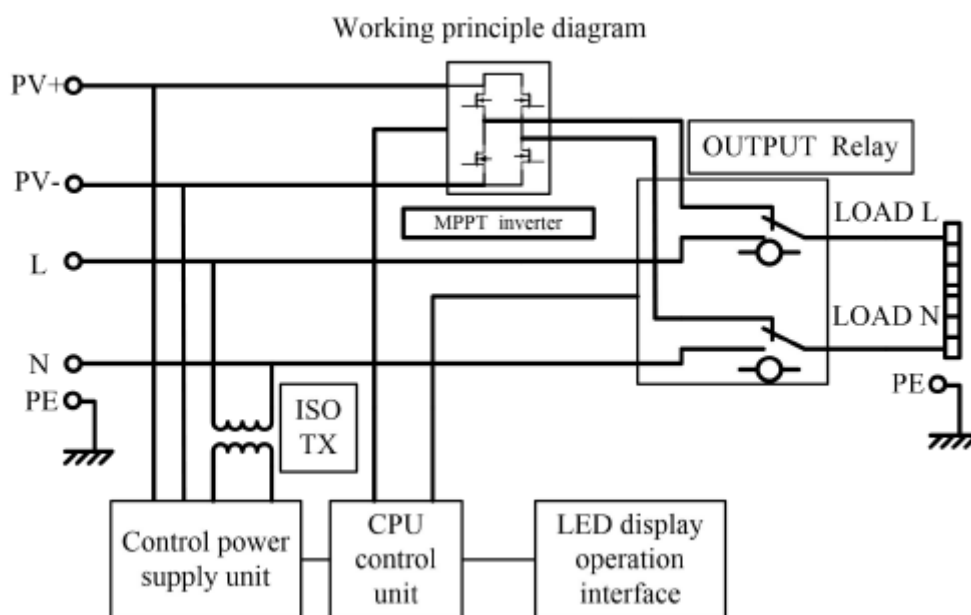

3

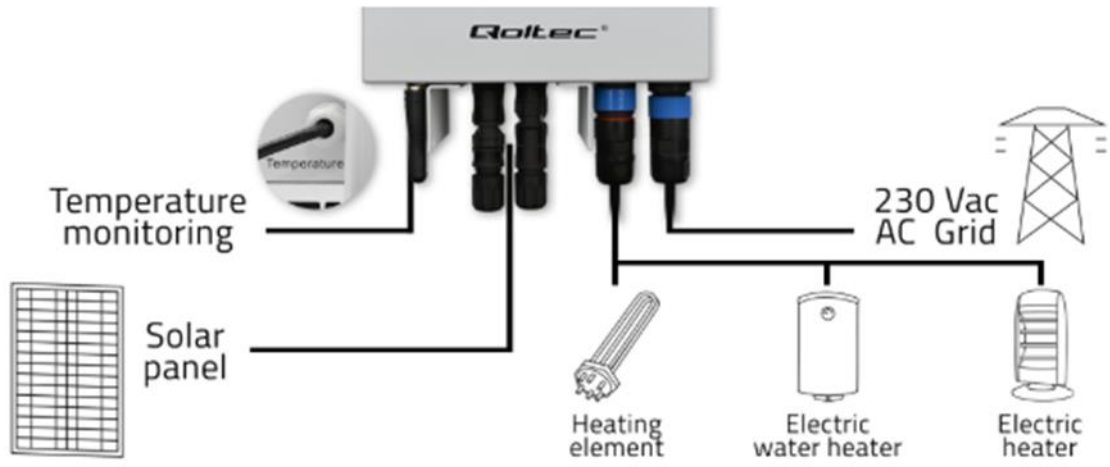

4

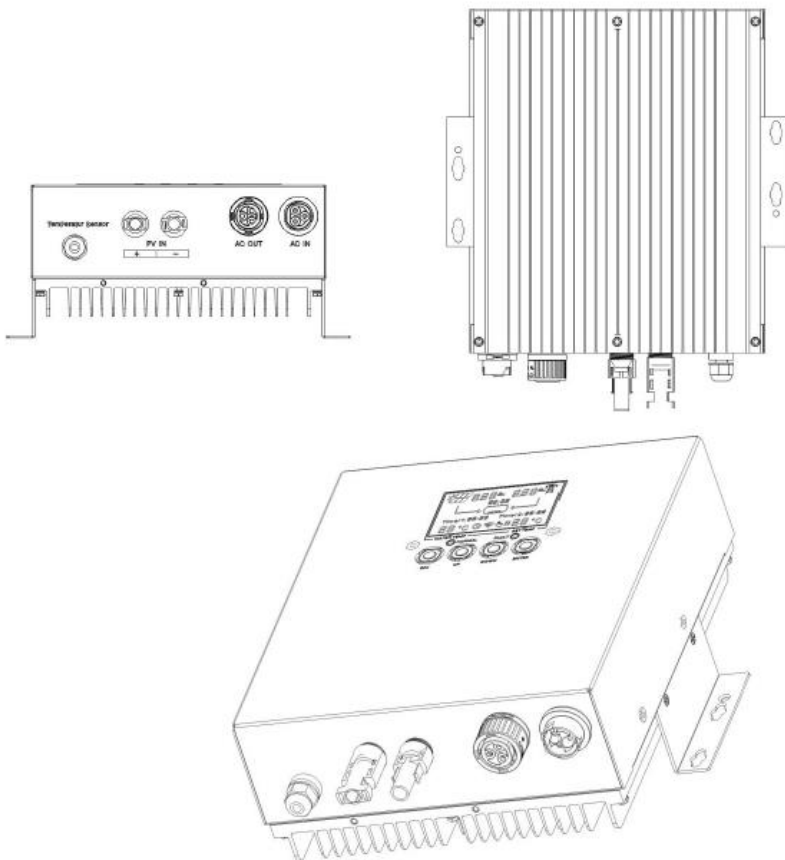

5

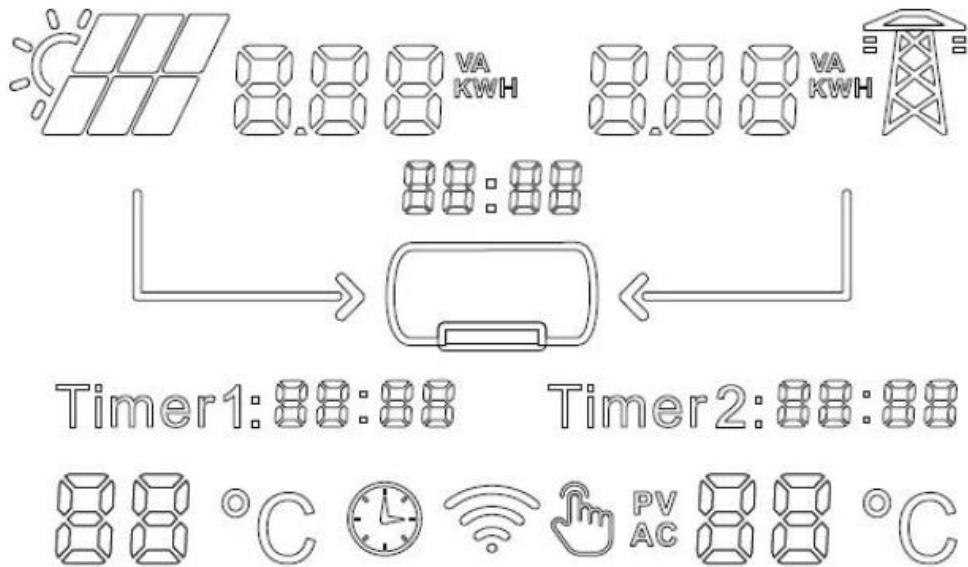

6

88:88

7

Timing1:88:88 Timing2:88:88

8



9



10

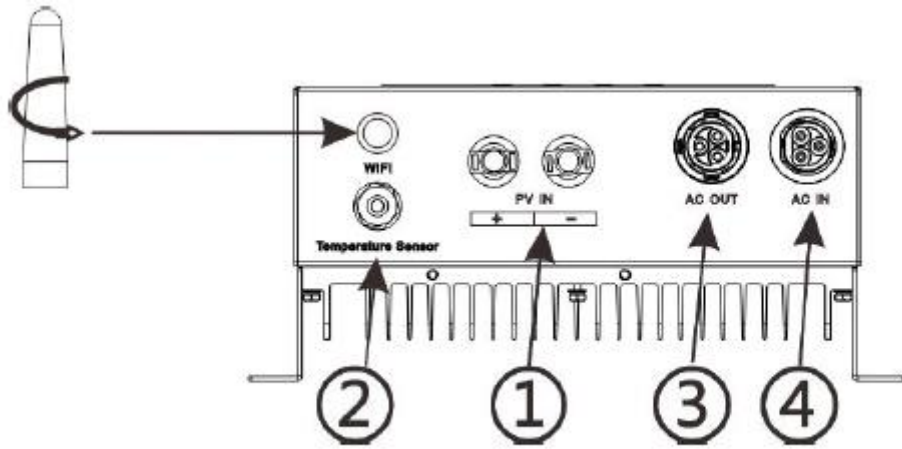

11

1.1 APP Download



Android



IOS