

Qoltec[®]



User manual

Type 2 EV Charging Station for electric and
hybrid cars, 22kW 32A

Model: 52723

Introduction

Thank you for your trust and for purchasing our product. We have made every effort to ensure that the product meets your expectations.

This manual contains important information regarding the safety and operation of the device. If you have any questions after reading this manual, please contact NTEC sp. z o.o.

Safety information

Installation requirements and safety guidelines for the EV charger

Note: Installation must be carried out in accordance with the local electrical regulations applicable in the country of installation and by a suitably qualified person.

Before installing the charger, it is essential to check the condition of the existing installation. For the charger to operate safely, reliably and in accordance with its specifications, the electrical installation must be properly prepared.

Before commissioning the installation, the installer should verify the effectiveness of the electric shock protection, the continuity of the protective conductor, the earthing parameters and the correct operation of the safety devices.

The manufacturer is not liable for the consequences of incorrect installation.

Installation requirements

1. The installation and connection of the charger must be carried out by a qualified electrician. Incorrect installation may result in damage to the device or a risk to life.
2. The EV charger should be connected to a separate, dedicated electrical circuit. It must not be connected to a circuit shared with other high-power devices.
3. In the event of an unstable mains supply, surge protection is essential – failure to use it may result in damage to the charger. It is recommended to use surge protection devices (SPDs) in the power supply system, particularly in areas prone to mains instability, lightning strikes or frequent voltage spikes.

4. Do not use extension leads, splitters, adaptors or uncertified adaptors. The charger should only be connected to an installation that complies with local regulations and the device's specifications.
5. Check the terminals in the distribution board, cable connections and the condition of the contacts, and ensure there is no play or signs of overheating.
6. Take into account the risk of voltage drops – if the cable run is too long or the cable cross-section is incorrectly selected, these can cause slower charging, interruptions to the charging session, device errors and excessive heating of the installation.
7. Before installation, verify the power supply network parameters – in particular, voltage compatibility with the charger's requirements, the number of phases, the correct phase sequence and presence of phases, and voltage stability under load; in three-phase installations, additional consideration must be given to the risk of phase imbalance, the loss of one of the phases, and the occurrence of excessively low or high voltage on individual phases.
8. The charger should not be installed in areas at risk of flooding, on damaged or unstable surfaces (walls or posts), near heat sources, or in places where the cable or plug may be exposed to mechanical damage.

The manufacturer/supplier accepts no liability for any malfunction of the device resulting from:

1. inadequate condition of the electrical installation,
2. lack of required safety measures,
3. incorrect earthing,
4. voltage fluctuations outside the permissible range,
5. installation not in accordance with the instructions and local standards.

Safety precautions

1. Protect the device from rain and moisture – use only in covered areas; do not immerse the control module in water.
2. Do not tread on, pull, bend or tie the cable, and do not use the device if the cable is damaged.
3. Do not drop the control module or place heavy objects on it.

4. Do not use the device near sources of high temperature or outside the operating temperature range of -30°C to +55°C.
5. Do not place the device in a car or in a closed, unventilated space whilst charging.
6. The device may only be used in an installation equipped with a residual current device (RCD).
7. Do not insert your fingers or any objects into the charging port.
8. Do not use extension leads or additional adapters.
9. The device is intended solely for charging electric vehicles.
10. In the event of a fault, do not attempt to repair the device yourself – contact your dealer or a service centre.

WARNING!

Incorrect connection of the protective conductor (earthing) may result in a risk of electric shock. If you are unsure whether the product is correctly earthed, contact a qualified electrician or service centre. Do not modify the plug supplied with the product. If the plug does not fit the socket, have a suitable socket fitted by a qualified electrician.

Charging station design

Figure 1 in the appendix

Control box → Control box housing

LOGO indicator light → LED indicator (logo)

Display screen → Display

Touch button → Touch button

Card swipe area → Card reading area (RFID)

Vehicle connector protective cover → Vehicle connector protective cover

Vehicle connector → Vehicle connector

Single-phase 230V → Single-phase 230V

Three-phase 400V → Three-phase 400V

Display description

Figure 3 in the appendix

Charging time → Charging time

Charged amount → Amount of energy charged

Grounding status → Grounding status

WiFi status → Wi-Fi status

Current mode → Current mode

Real-time voltage → Real-time voltage

Real-time current → Real-time current

Real-time power → Real-time power

Status prompt → Status message

Host temperature → Host temperature

Delay → Delay

Timing → Schedule / Timer

Statuses displayed on the screen

Figure 4 in the appendix

Ready → Ready

Swipe card → Swipe card

Connect → Connect

Charging → Charging

Complete → Complete

Warning → Warning

Installation instructions

Installation tools (Figure 5 in the appendix)

1. Hammer drill – used to drill holes in the wall.
2. Phillips screwdriver – used for fitting screws and connecting wires to terminals.
3. Multimeter – used to measure voltage.
4. Wire stripper / wire cutter – used for stripping insulation and cutting wires.
5. Insulating tape – for securing wire connections.

Method of mounting on a column (post)

Installation steps:

1. Route the power cable from the bottom of the column upwards, feeding it through the entry hole, then pull the cable out.
2. Use screws to secure the column to a stable surface, such as a concrete base.
3. First, remove the mounting plate from the unit's body.
4. Use the screws corresponding to the three holes to secure the mounting plate to the column.
5. Hang the unit body onto the mounting plate from top to bottom and tighten the screws connecting the unit body to the mounting plate.

Figure 6 in the appendix

Wall-mounting method

Installation steps:

1. First, remove the mounting plate from the wall and the unit body.
2. Use the positioning card (template) to mark and drill three holes for the mounting screws in the wall.
3. Screw the screws into the prepared holes in the mounting plate on the wall, ensuring the correct orientation (top/bottom).
4. Align the screws with the holes in the wall and securely fasten the mounting plate to the wall.
5. Hang the unit body onto the mounting plate from top to bottom and tighten the screws securing the unit body to the mounting plate.

Figure 7 in the appendix

Labels in the diagram:

Wall mount plate → Wall mounting plate

Charging pile → Charging station

Using the charger

Figure 8 in the appendix

1. Check that the power LED on the wall charger is lit with a steady green light.
2. Remove the vehicle connector from the wall charger's holder (docking station).
3. Connect the vehicle connector to the charging socket in the vehicle.
4. Charging will start when you tap your card or via the app. The electric vehicle will monitor the charging process.
5. Once charging is complete, disconnect the vehicle connector from the charging socket and place it back in the wall charger's holder.
6. Make sure the output cable is neatly arranged in the cable holder.

LEDs

1. LED (green) – steady light

The wall charger is switched on and in standby mode.

2. LED (green) – flashing

The vehicle connector is plugged into the vehicle's charging socket.

3. LED (blue) – pulsing ('breathing')

Charging is in progress.

4. LED (blue) – steady light

The charging process is complete.

5. LED (red) – flashing

Error. Please refer to the troubleshooting guide.

Figure 9 in the appendix

Markings and connection diagrams

Three-phase 400V → Three-phase 400 V power supply

Single-phase 230V → Single-phase 230 V power supply

Electrical switch → Electrical switch

Household meter → Electricity meter

Total input → Power input

L1 / L2 / L3 → Phase wires

N → Neutral wire

PE → Protective conductor (earth)

Technical specifications

Model		52723
Input	Number of phases	Three
	Frequency	50Hz/60Hz
Charging current adjustment		13A/16A/20A/24A/32A
Plug		CEE32A
Output	Current	32A max
	Power	22kW
	Voltage	380–400V
Conditions	Operating temperature	-30°C to +55°C
	Humidity	5%–95%
Charging interface		IEC 62196-2
Cable length		5m
Protection	Overvoltage/undervoltage protection, Thermal protection	
	Overcurrent protection, earth leakage protection	

	Earth fault protection	
	Ingress protection	IP66

Troubleshooting

LED behaviour	Problem	Solution
The charging status LED flashes red 3 times	Voltage too high	Disconnect the vehicle connector, then reconnect it to the vehicle's charging socket. If the problem persists, contact a qualified electrician to check the AC power supply.
The charging status LED flashes red 4 times	Voltage too low	Disconnect the vehicle connector, then reconnect it to the vehicle's charging socket. If the problem persists, contact a qualified electrician to check the AC power supply.
The charging status LED flashes red 5 times	Overcurrent	Disconnect the vehicle connector, then reconnect it to the vehicle's charging socket.
The charging status LED flashes red 6 times	Overheating	Disconnect the vehicle connector, then reconnect it to the vehicle's charging socket. If the problem persists, disconnect the vehicle connector and allow the device to cool down before attempting to charge again.
The charging status LED flashes red 8 times	Current leakage	Restart the device by switching the RCD off and on again, then disconnect and reconnect the charging station. If the problem persists, contact a qualified

		electrician or technical support.
The charging status LED flashes red 9 times	Emergency stop	Check whether the red emergency button on the side of the controller housing has been pressed. After using it, turn the button in the direction indicated on the housing to restore normal operation.
The charging status LED flashes red 10 times	CP error	Restart the device by switching the circuit breaker off and on again, then disconnect and reconnect the charging station. If the problem persists, contact a qualified electrician or technical support.

Other advanced features

Enabling or disabling the card authorisation function via software

Figure 10 in the appendix

01 Press both buttons simultaneously and hold for 10 seconds to display the settings interface.

02 Press the left button to disable the card authorisation function.

Press the right button to enable the card authorisation function.

Figure 11 in the appendix

01 Press and hold the left button to go to the card authorisation screen.

If no card is detected or no operation is performed within 10 seconds, the screen will automatically return to the main interface.

Figure 12 in the appendix

02 After presenting the card, enter the **settings menu**.

Figure 13 in the appendix

03 Menu button functions:

Left button – select an option

Hold down the left button – go back

Right button – confirm

Figure 14 in the appendix

04 Menu functions:

Main menu (level 1): parameter settings, operating status information

Second-level menu:

enabling / disabling card authorisation

enable/disable emergency mode with earthing

reset Wi-Fi connection

DOWNLOADING AND USING THE APP

► Scan the QR code to download the app:

Smart Life or Tuya Smart

Figure 15 in the appendix

► Once the app has launched, tap the '+' icon in the top right-hand corner to automatically search for the device.

Enable Wi-Fi and Bluetooth, then start the search.

► Enter the Wi-Fi network name and password, wait until the charging device has been successfully connected to the internet, after which you will be taken to the charging interface in the app.

APP SETUP STEPS

1. Tap to open the app
2. Top right corner → "+" → select "Add device"
3. Tap the product icon

Figure 16 in the appendix

4. The first connection requires the phone and the device to be connected to the same Wi-Fi network
5. Connection successful
6. Setup complete

Figure 17 in the appendix

7. Adjusting the charging current
8. Setting the charging time
9. Setting the charging delay
10. Start charging

Figure 18 in the appendix

Maintenance

1. Keep the charger clean by using a soft, dry cloth to remove dust and dirt. Do not use chemicals.
2. Regularly check the power cables and connectors for damage, such as fraying, cracks or loose connections.
3. Ensure that the ventilation openings are clean and unobstructed to ensure proper cooling.
4. Avoid contact with water or other liquids to prevent electrical damage.

Disposal

This product is subject to the regulations on the disposal of electrical and electronic equipment (WEEE). Take it to an e-waste collection point that ensures safe recycling in accordance with GPSR standards. Check where the nearest e-waste collection points are at . If you have any questions regarding disposal, please contact the manufacturer or an authorised service centre.

Warranty and servicing information

The product is covered by a 24-month manufacturer's warranty, effective from the date of purchase. The warranty covers all material and manufacturing defects. Please contact our service department in the event of any problems with the device to ensure prompt and professional assistance. The warranty does not cover damage resulting from misuse, drops, mechanical damage, unauthorised repairs or attempts at disassembly.

Attachement 1

1

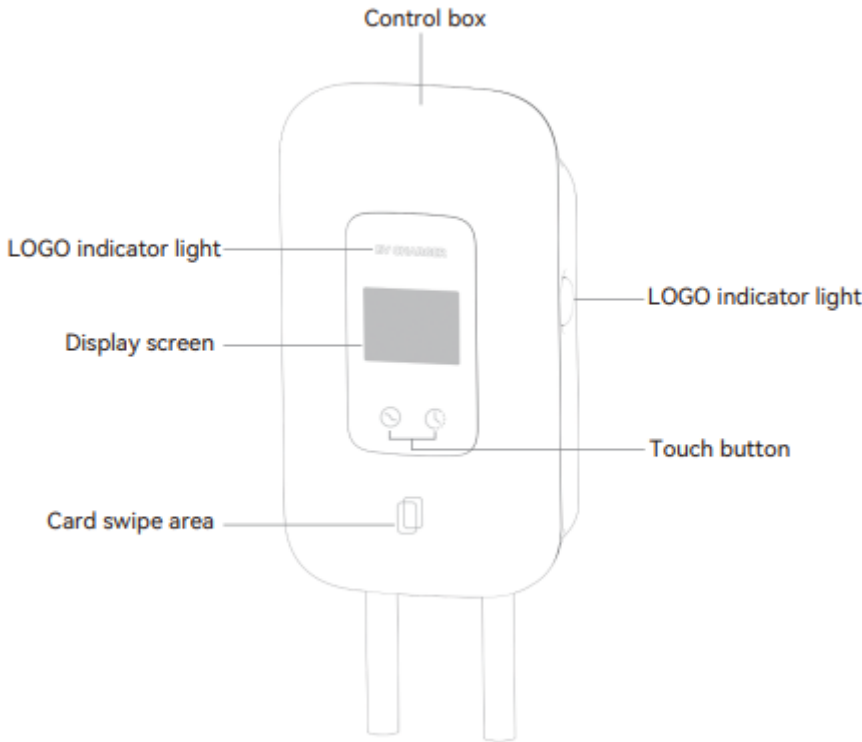

2

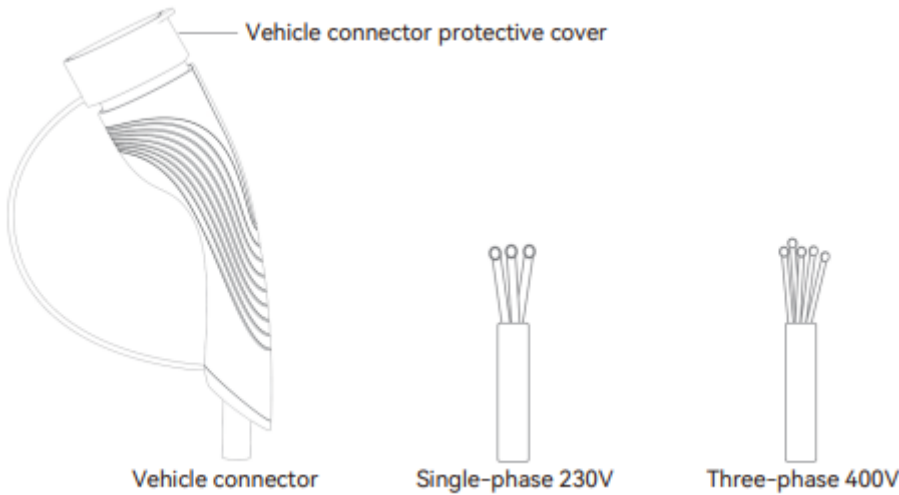

3

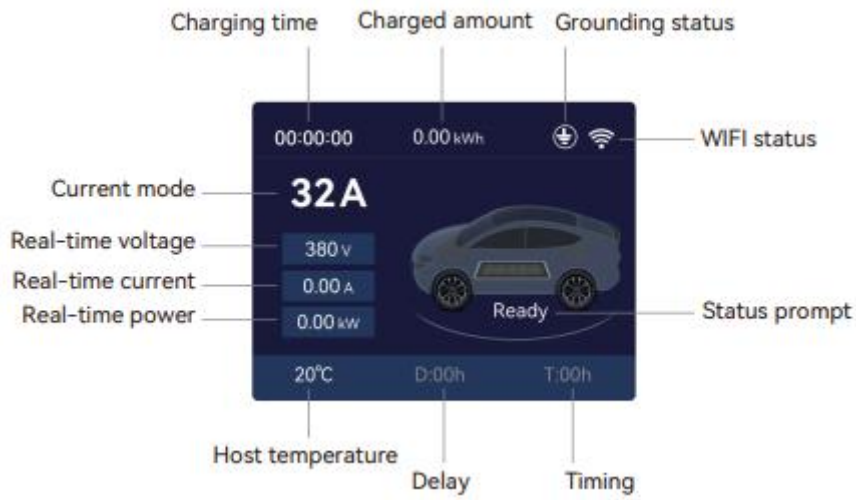

4



5

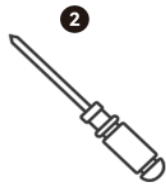

6

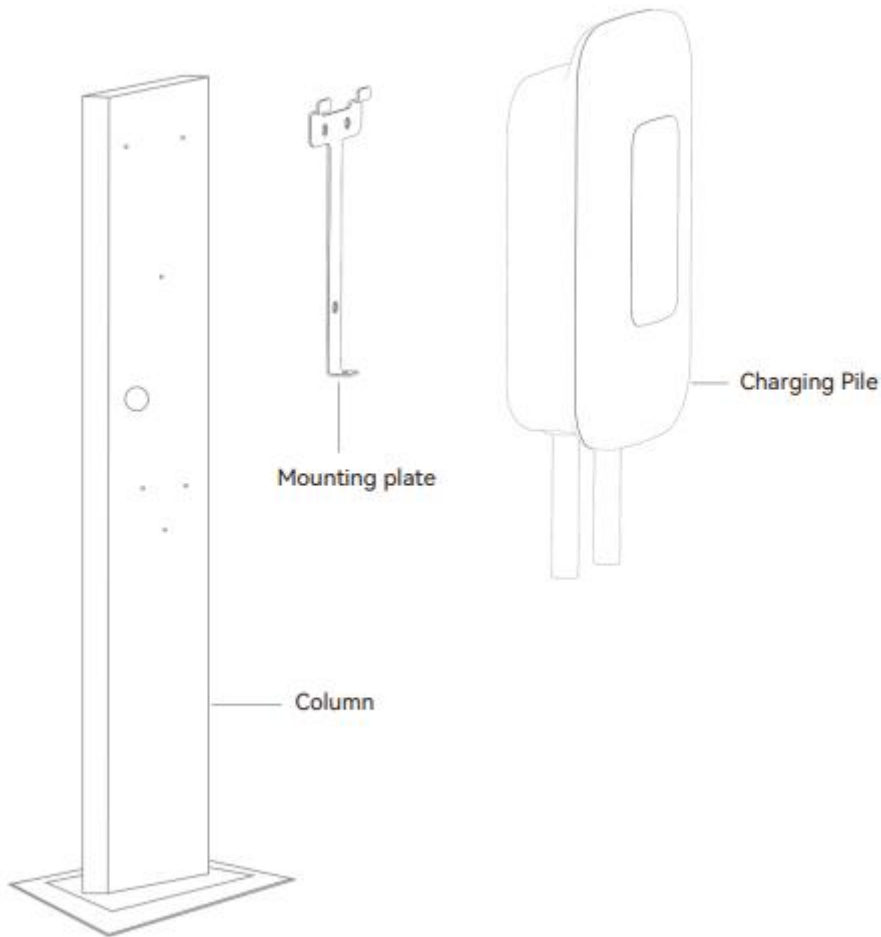

7

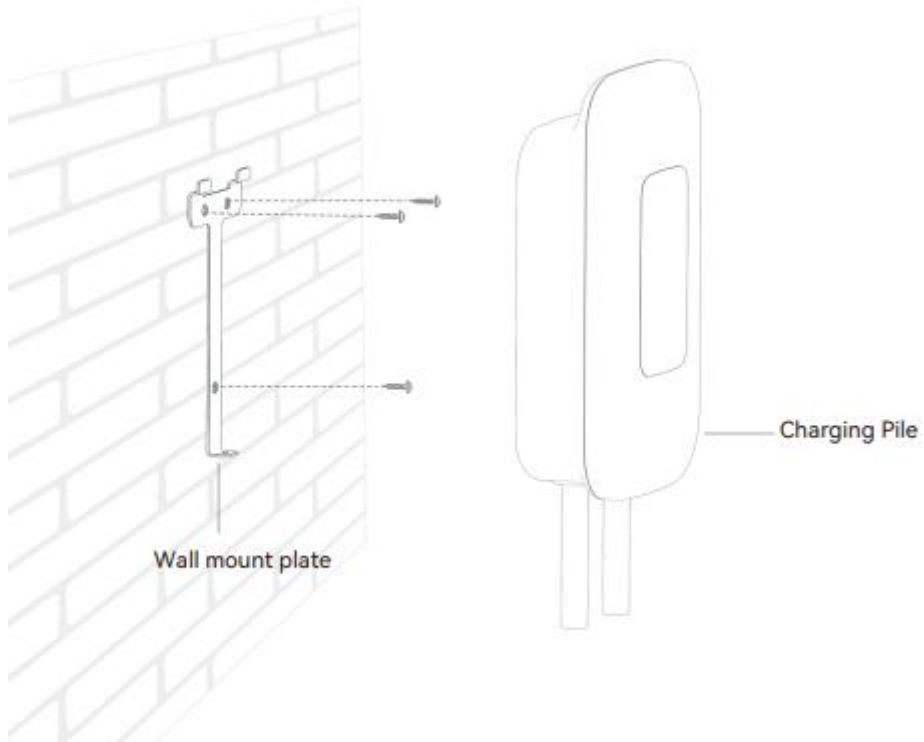

8



Three-phase 400V



Single-phase 230V





10



11



12



13



14



15



Smart Life



Tuya Smart

16



17



18

