

***Qoltec***<sup>®</sup>



# **INSTRUCTION MANUAL**

## **MPPT solar controller**

**Model : 53660 53661 53662 53663 53664 53665**

**EN**

## **INTRODUCTION**

Thank you for your trust and for choosing our product. We are confident that the product will meet your expectations. This manual will help you get acquainted with the appliance and facilitate the configuration process, as well as help you with any problems that may arise during the operation of the appliance. In case of any problems, please read this manual before contacting customer service.

## **INFORMATION ABOUT THIS MANUAL**

This manual describes, installation, operation and troubleshooting of this appliance. Please read this manual carefully before installing and operating the unit.

## **SAFETY INSTRUCTIONS**

The installer of the appliance should be electrically qualified and familiar with the design and wiring of solar systems.

Carefully read the instructions and precautions in this manual before starting the installation.

- Do not disassemble the product into parts for self-repair.
- Ensure that all power supplies are disconnected before installing or moving the unit.
- Use insulated tools when connecting the power cord.
- Do not wear jewellery during installation.
- Make sure the power cord connection is solid to prevent the connector from overheating and causing a fire due to a loose cord.
- Use cables and switches with the correct specifications.

## **ABOUT THE PRODUCT**

Solar charge controller designed to manage the charging process of batteries in photovoltaic systems. Equipped with maximum point tracking technology (MPPT), the controller ensures maximum efficiency and optimisation of solar panels. An easy-to-read LCD display allows monitoring of the unit's operating status, load, system parameters and battery charge status in real time. A built-in temperature sensor monitors battery temperature, adjusting charging parameters.

The controller uses MPPT technology, which maximises energy efficiency by enabling optimal use of solar energy. This allows the system to continuously monitor and adjust

the voltage and current from the photovoltaic panels to ensure maximum power point. This advanced energy management allows the highest possible efficiency from the solar panels, even under varying weather conditions such as partial shading or changes in sunlight intensity.

Figure 1

Follow the steps below to connect the cables and install them.

Illustration 2







**NOTE :**





1. This MPPT series is a controller with a common positive polarity. The PV system, battery and load can all share a positive grounded pole at the same time.
2. If there is an inverter or other device with high inrush current in the system, please connect the inverter directly to the battery. Do not connect it to the load terminal of the controller.

**LCD display**

Figure 3

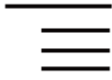
**Feature description**

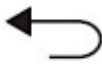
Feature	ICO		Status	
	PV operation			day
			Charging	
Battery			Discharged/ Battery capacity	
			Battery type	
Load			With load	Without load

	Designation			Function
MENU				Briefly press to toggle down; press and hold for 3 seconds to enter the next interface.
SETTING				Briefly press to toggle up; press and hold for 3 seconds to exit without saving.

## Start screen

Start-up interface

Battery voltage

Figure 4

1. The system automatically recognises the connected LCD screen at start-up.
2. The interface displays the battery voltage  
 Note : On the first interface, hold down the 'MENU' button to enter the second level interface. After 15 seconds of inactivity, the system will automatically switch back to the first interface."

## Load on/off

Figure 5

Briefly press the 'SET' button to switch the load on/off

Figure 6

To save the settings, press and hold the "MENU" button for 3 seconds. Pressing and holding the "SET" button for 3 seconds will switch to the home page without saving the settings.

Figure 7

## Main screen

Home page

Battery  
temperature

Charging  
current

Illustration 8

Figure 9

Discharge  
current

Cumulative discharge AH

When the controller is powered up, the LCD screen goes to the home page. On this page, a short press of the "MENU" or "SET" buttons allows you to switch between the main pages.

Main page

Continue charging

Constant charging voltage (CV)

Figure 10

Charging  
alignment

Absorption charging

Figure 11

System voltage

Battery  
type

Picture 12

Low voltage  
regeneration

Protection  
against low  
voltage

Low-voltage protection

Figure 13

Temperature  
compensation

Load operation mode

Illustration 14

On the main page, press and hold the "MENU" button for 3 seconds to access the settings page, then briefly pressing the "MENU" or "SET" buttons will allow you to switch between the settings pages.

## **Voltage settings**

Figure 15

Illustration 16

Once in the settings pages, go to the system voltage page, press and hold the "MENU" button for 3 seconds until "auto" starts flashing. Then briefly press the "MENU" or "SET" buttons to set the system voltage to 12V or 24V.

## **Battery type**

On the home page, press and hold the "MENU" button for 3 seconds to access the settings page, then a short press of the "MENU" button will switch to the battery type page (user mode 1).

Once in the battery type page (user mode 1), press and hold the "MENU" button for 3 seconds to access the battery type selection pages. Then a short press of the "MENU"

or "SET" buttons will allow you to switch between gel, sealed, lead acid and lithium batteries.

On each lithium battery page, press and hold the 'MENU' button for 3 seconds to enter the lithium battery capacity setting programme. At this time, the parameters on the screen will start flashing. Continue holding the "MENU" button for 3 seconds until the parameter switches to battery capacity. A short press of the "MENU" or "SET" buttons will allow you to set the capacity of the currently connected lithium batteries. Once the parameters have been set, save the data by pressing and holding the "MENU" button for 3 seconds.

### **The battery type displays the graph**

**Figure 17**

### **Load operation mode**

**The controller defaults to a 24-hour load and offers 4 load modes to choose from.**

<b>Code</b>	<b>Codes for load modes</b>
<b>LD1</b>	<b>Regular mode</b>
<b>LD2</b>	<b>Lighting control mode</b>
<b>LD3</b>	<b>Lighting and time control mode</b>
<b>LD4</b>	<b>Reverse lighting control mode</b>

LD1 : The load operates normally and can be switched on or off manually

LD2 : Load automatically turns on after dusk and turns off at dawn.

LD3 : Load operating hours after dusk and before dawn (automatic dusk recognition based on local conditions).

LD4 : Load automatically switches on at dawn and switches off at dusk.

**Figure 18**

If the lighting and time control mode is selected, the user goes to the settings interface to configure the duration of the DC output. Once the duration is set, the LD3 mode configuration programme can be activated or deactivated by selecting 'on' or 'off' in the switch interface.

**Figure 19**

## PV voltage page

**Figure 20**

**Long press the "SET" button for 3 seconds to switch between the main and PV voltage side.**

## Setting the equalisation time

After switching to the equalisation charge page from the main page, long press the "MENU" button for 3 seconds when the parameter starts flashing to switch to the equalisation charge time setting page. Press the "MENU" or "SET" button briefly to increase or decrease the time.

**Figure 21**

## Setting the absorption charge time

Once you have reached the absorption charge page from the main page, press and hold the "MENU" button for 3 seconds when the parameter starts flashing. Continue holding for a further 3 seconds to access the absorption charge time settings page. Then use short presses of the "MENU" or "SET" buttons to increase or decrease the time.

**Figure 22**

## Protection functions

Protection	Condition	Status
Solar panel polarity reversal	The solar panel can be inverted if the battery is not connected.	Controller is not faulty
Battery is reversed	Battery may be faulty if the solar panel is disconnected	
Battery voltage is too high	Battery voltage reaches the over voltage point	Stop charging and discharging
Battery is over-discharged	Battery voltage drops below the undervoltage	Stop discharge

	point	
Overload	Load current exceeds the rated value	Switch off output

## Troubleshooting

Error code	Cause	Solution
The PV installation indicator is off even though there is enough sunlight."	"The solar panels are disconnected."	Check that the connection of the PV installation is correct."
No signal on the LCD display when the connection is correct.	1. Battery voltage is less than 8 V. 2. the solar panel voltage is less than the battery voltage."	1. check the battery voltage (at least 8 V to activate the controller). 2. the solar panel voltage must be higher than the battery voltage.
E1	Battery is excessively discharged	The load will stop automatically and be restored when the battery voltage reaches 12.6 V."
E2	Battery voltage is too high	Ensure that the established disconnection voltage at high voltage is higher than the battery voltage, then reconnect the PV installation
E3	Overload	Reduce load or check load connection
E5	Overheated controller	Controller will restart after cooling down.
E6	Solar panel input voltage is too high	Check the solar panel voltage and reduce the number of solar panels connected in series."
E7	The controller will restart after adjusting the system voltage.	No operation

## Technical specification

	53660	53661	53662	53663	53664	53665
--	-------	-------	-------	-------	-------	-------

Nominal charging current	<b>10A</b>	<b>20A</b>	<b>30A</b>	<b>40A</b>	<b>50A</b>	<b>60A</b>
<b>INPUT</b>						
Maximum PV input power	<b>130W(12V ) 260W(24V )</b>	<b>260W(12V ) 520W(24V )</b>	<b>390W(12V ) 780W(24V )</b>	<b>520W(12V ) 1040W(24V )</b>	<b>650W(12V ) 1300W(24V )</b>	<b>780W(12V ) 1560W(24V )</b>
System nominal voltage	<b>12/24 AUTO</b>					
Maximum open voltage (Voc) of PV solar panel	<b>&lt;60V(24V)</b>	<b>&lt;60V(24V)</b>	<b>&lt;75V(24V)</b>	<b>&lt;100V(12V/24V)</b>		
<b>OUTPUT</b>						
Nominal discharge current	<b>10A</b>	<b>20A</b>	<b>20A</b>	<b>20A</b>	<b>20A</b>	<b>30A</b>
Battery type	<b>User default settings : Sealed, Flooded, Gel" LiFePO4, Li(NiCoMn)O2</b>					
Equalising charge voltage	<b>Maintenance-free lead-acid battery ; 14.6V Lead-acid gel battery (GEL);NO, flooded lead-acid battery 14.8V</b>					
Absorption charging voltage	<b>Maintenance-free lead-acid battery ; 14.4V Gel lead-acid battery (GEL);14.2V, flooded lead-acid battery 14.6V</b>					
Sustaining charge voltage	<b>Maintenance-free lead-acid battery Lead-acid gel battery (GEL), flooded lead-acid battery 13.8V</b>					
LVR	<b>Maintenance-free lead-acid battery Gel sealed lead-acid battery (GEL), flooded lead-acid battery 12.6V</b>					
LVD	<b>Maintenance-free lead-acid battery Lead-acid gel battery (GEL), lead-acid flooded battery 10.8V</b>					
Light control voltage	<b>5V/10V/15V/20V</b>					
Temperature compensation factor	<b>-4mV/°C/2V (25°C)</b>					
Static loss	<b>24V(&lt;50mA)/ 48V(&lt;35mA)</b>					
Voltage drop across discharge	<b>≤0.2V</b>					

loop		
Operating temperature	<b>-20°C~+55°C</b>	
Storage temperature	<b>-30°C~+80°C</b>	
Operating humidity	<b>≤90%, non-condensing</b>	
Degree of protection	<b>IP30</b>	
Type grounded	<b>Positive earthing</b>	
Mounting hole	<b>Ø5mm</b>	
Effectiveness	<b>95%</b>	
Display	<b>LCD</b>	
Communication	<b>2x USB , Bluetooth</b>	<b>Bluetooth</b>

**The previous parameters are for a 12V system and a temperature of 25 °C. For 24V system, max. 2x36V**

### **Solar Power 2.0 APP**

1. Scan the QR code to download the app .

Figure 23

2. Activate application

Illustration 24

Illustration 25

Illustration 26

Illustration 27

Illustration 28

Attachment 1

1

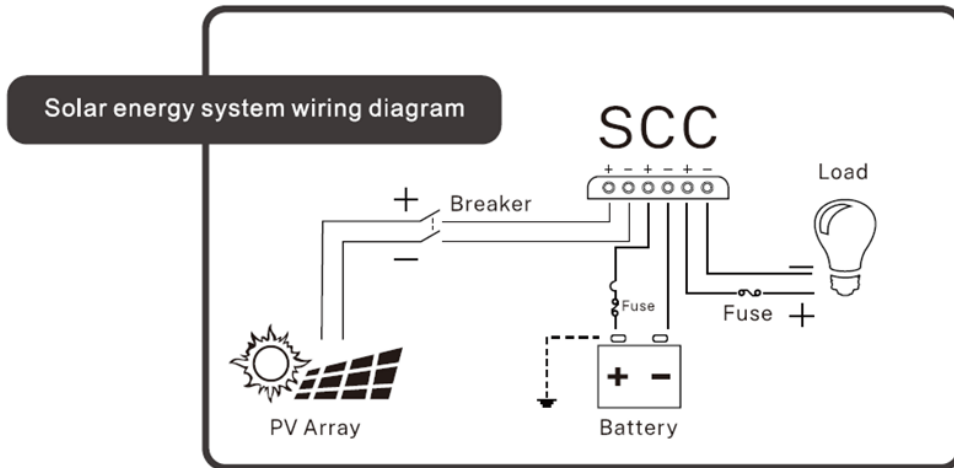

2



3

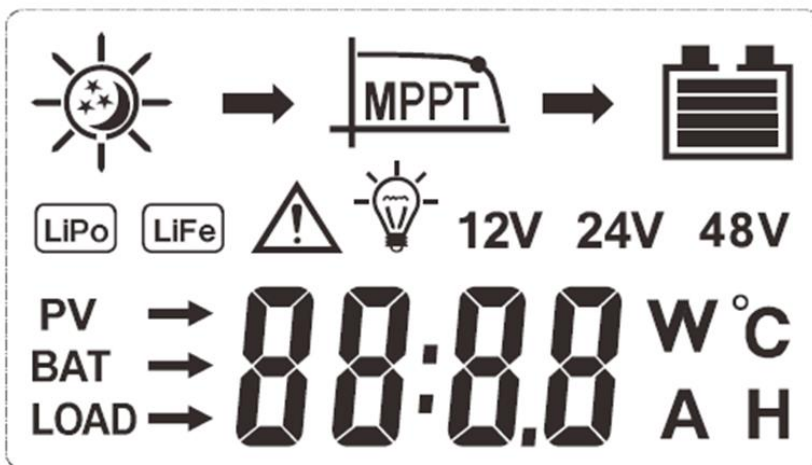

4

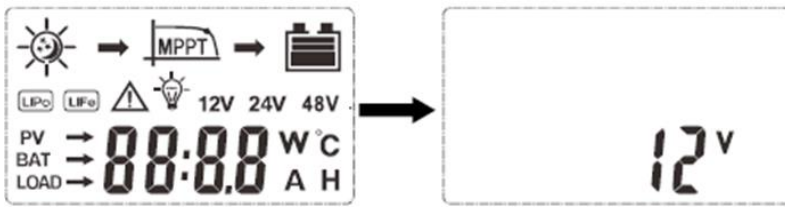

5

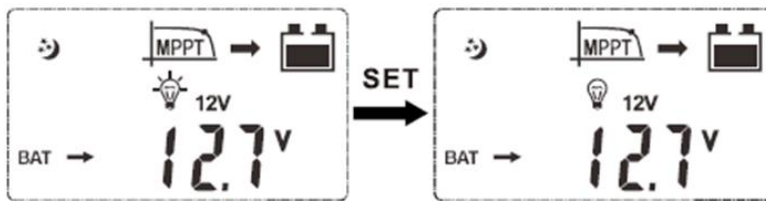

6

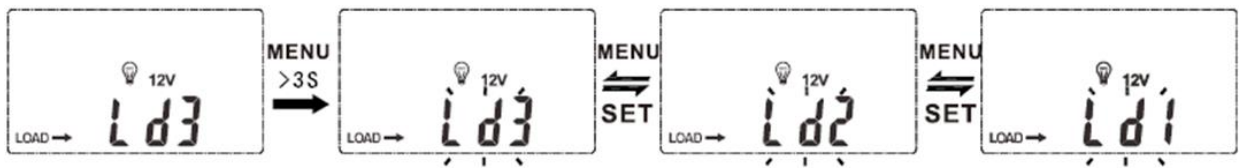

7

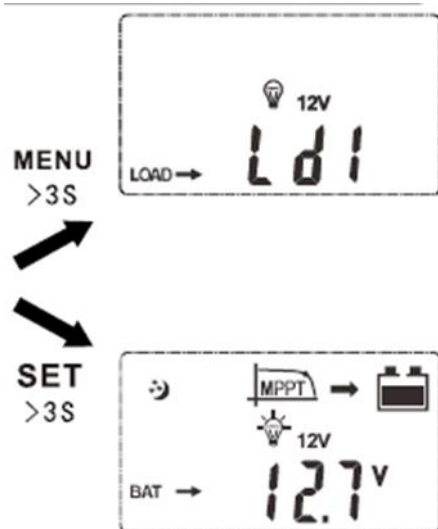

8

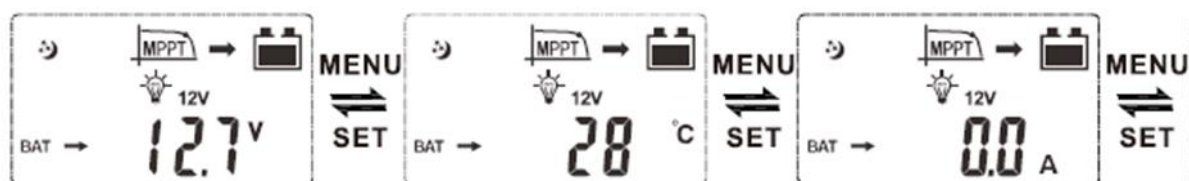

9

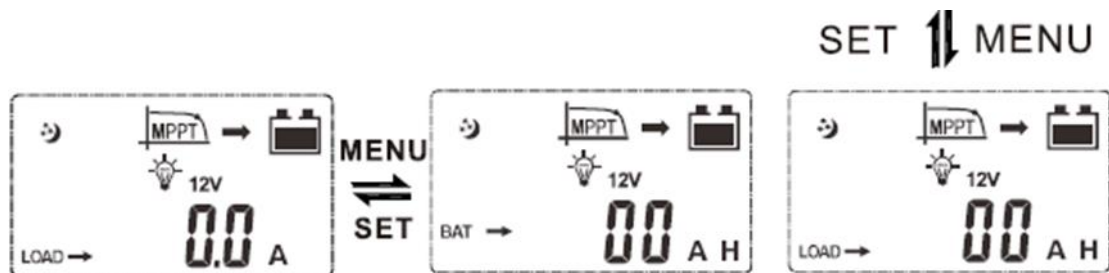

10

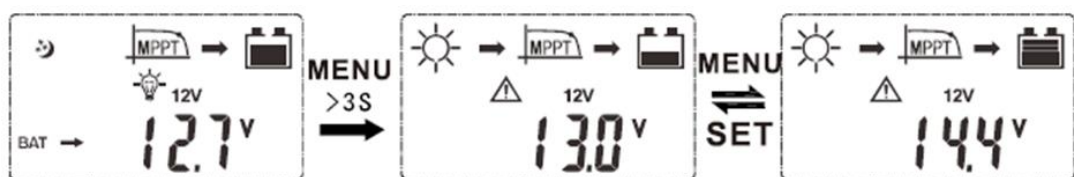

11

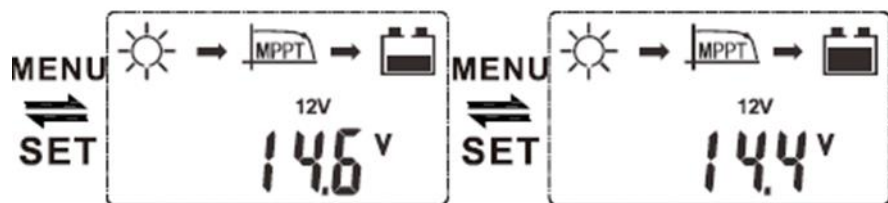

12



13

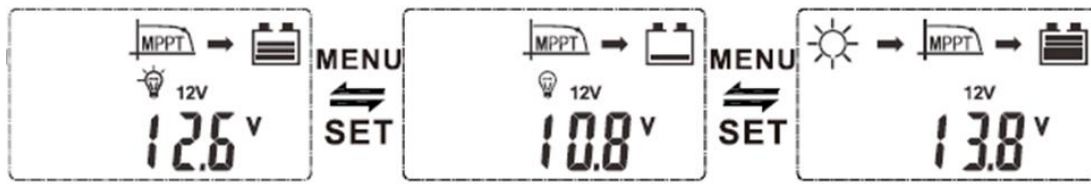

14

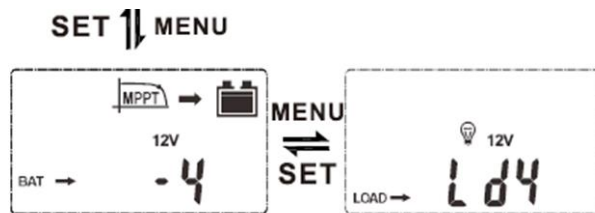

15

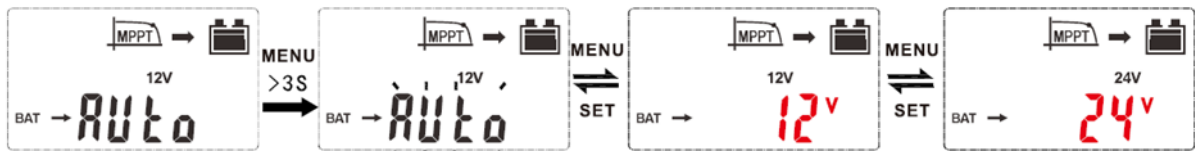

16

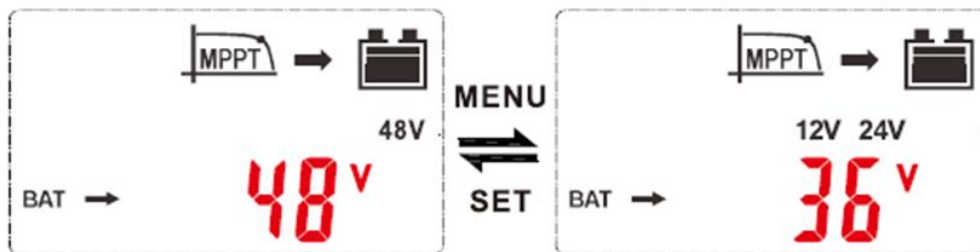

17

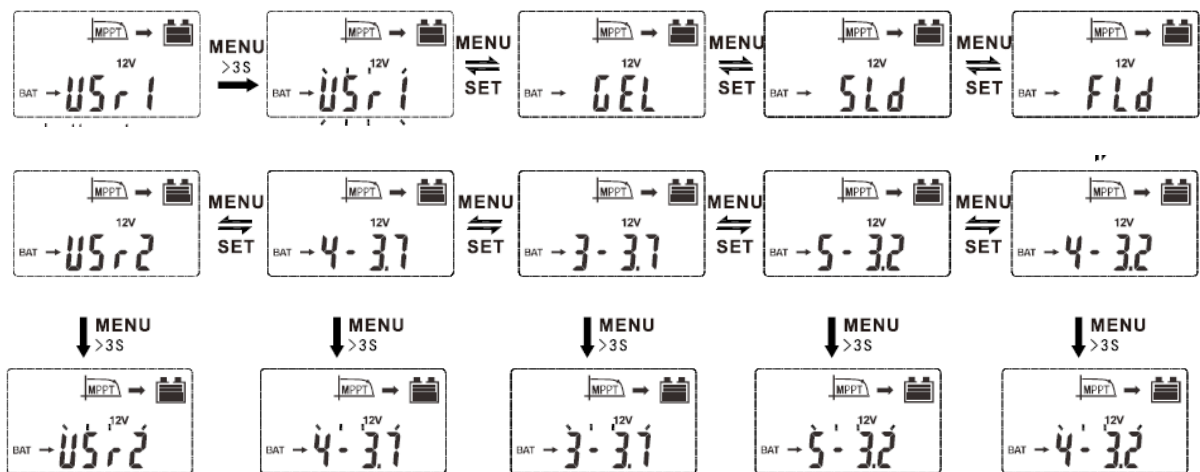

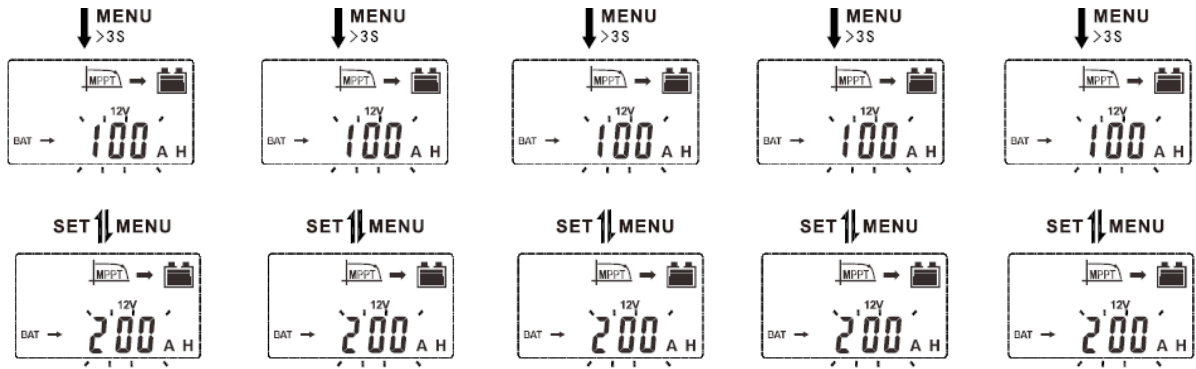

18



19

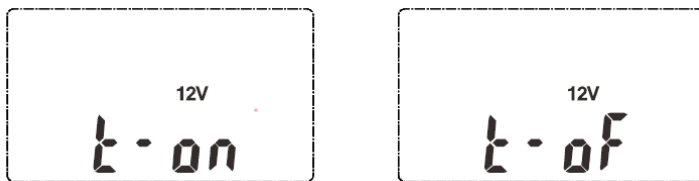

20

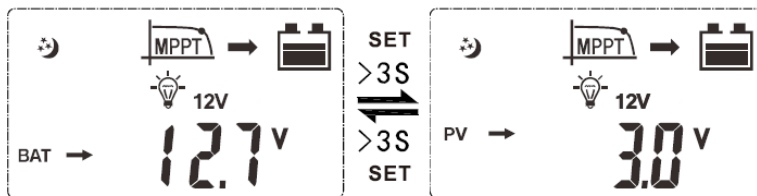

21

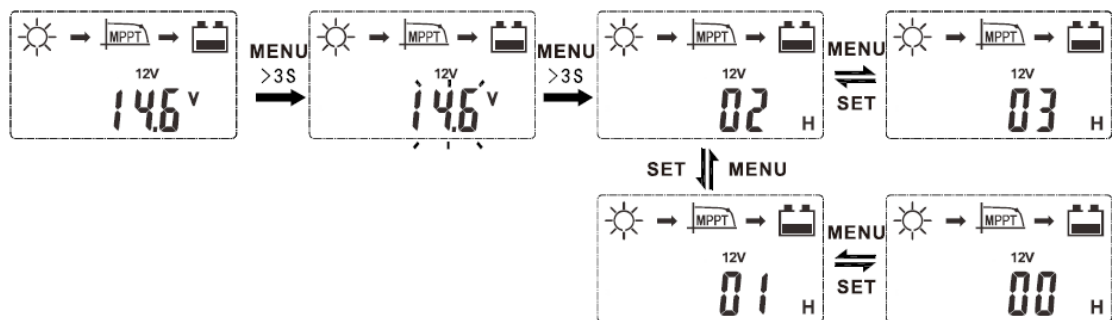

22

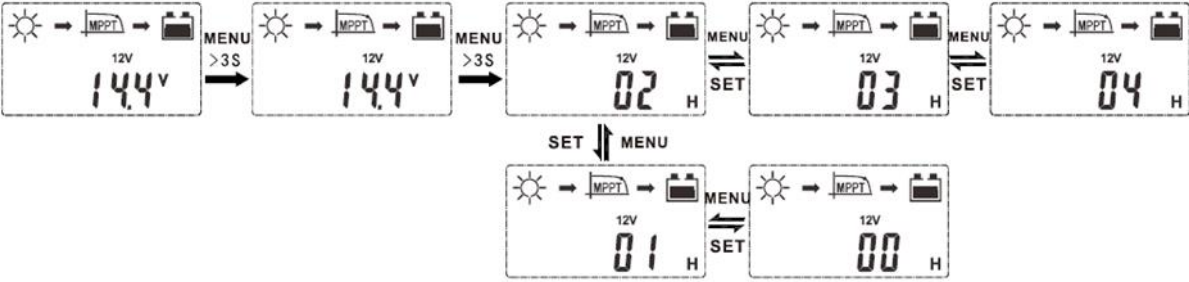

23



24

