

Qoltec[®]

Model: 53872

INSTRUCTION MANUAL

Solar inverter for water heating

Model : 53872

INTRODUCTION

Thank you for your trust and for choosing our Solar BOOST solar inverter with MPPT. We are confident that the product will meet your expectations. This manual will help you to familiarise yourself with the unit and facilitate the configuration process, as well as help you with any problems that may arise during the operation of the unit. In case of any problems, please read this manual before contacting customer service.

INFORMATION ABOUT THIS MANUAL

This manual describes the assembly, installation, operation and troubleshooting of this appliance. Please read this manual carefully before installing and operating the unit. The manual provides detailed information on the installation and operation of the MPPT solar electric heating controller.

SAFETY INSTRUCTIONS

The installer of the unit should be electrically qualified and familiar with the design and wiring of solar systems.

Read the instructions and precautions in this manual carefully before starting the installation.

- Do not disassemble the inverter for repair yourself.
- Make sure all power supplies are disconnected before installing or moving the unit.
- The unit gives off heat during operation, which can cause burns. Install the inverter in a location that is not easily accessible.
- Use insulated tools when connecting the power cable.
- Do not wear jewellery during installation.
- Ensure that the power cable connection is solid to prevent the connector from overheating and causing a fire due to a loose cable.
- Use cables and switches with appropriate specifications.

The following symbols described below appear in the manual to indicate potentially hazardous situations or to highlight important safety issues:

WARNING!

This sign indicates the risk of danger when carrying out certain activities.

NOTE!

This sign indicates the key operational steps that need to be taken to ensure the safe operation of the controller.

ABOUT THE PRODUCT

The ECO Solar Boost solar water heater inverter with MPPT technology is designed to deliver the electricity generated by the solar panels to the electric water heater with maximum efficiency thanks to MPPT technology. It converts the direct current from the photovoltaic panels into square wave alternating current, which can be directly connected to traditional water heaters. Equipped with a smart control function for intelligent switching between solar and grid power.

A description of the functions of the various parts of the unit is shown in the figure below.

Illustration 1

1. Reserved slots for WIFI (optional)
2. PV input terminal
 - + - Connect the positive (+) PV lead
 - Connect the negative (-) lead of the PV
3. Temperature sensor
4. AC output terminal interface
 - L - Connected to the L line of water equipment
 - N - Connected to N line of water equipment
 - PE - Grounding wire of water equipment
5. AC INPUT terminal interface
 - L - Connected to line L of the AC network
 - N - Connected to line N of the AC network
 - PE - Connected to the AC mains earth line
6. LED display: Displays current operating mode and current temperature

Green indicator: Indicates normal status

Red indicator: Indicates a fault condition

ESC button: Cancel/Return

UP key: Switch to previous mode

Down key: Switch to the next mode

ENTER button: Confirm

TECHNICAL SPECIFICATIONS

| | |
|----------------------|-------------------------------------|
| Rated power | 4000W |
| Scope of application | The MPPT water heater controller is |

| | |
|---|---|
| | suitable for heating only heating elements by solar energy, and the load on the controller can be used to connect AC equipment or heaters, heating power in the 420V/4000 watt range. |
| Characteristics | |
| Maximum input power from PV | 4000W |
| Solar input current | $\leq 20A$ |
| Solar input voltage range | 160 Vdc ~ 420 Vdc |
| MPPT operating voltage range | 120 Vdc ~ 410 Vdc |
| MPPT performance | >99% |
| PV input current range | $\leq 20A$ |
| AC | |
| Rated output of AC heating power (bypass) | 4000W |
| Rated voltage AC | 230 VAC |
| AC operating voltage range | 180 Vac ~ 260 Vac |
| Rated AC current | $\leq 20 A$ |
| Load requirements | |
| Load | The load should not be greater than 230V/4000W, and the resistance value must not be less than 13Ω . |

SCHEME OF OPERATION OF THE SYSTEM

Illustration 2

SYSTEM WIRING DIAGRAM

Illustration 3

INSTALLATION PROCESS

The installation environment is critical to the performance and service life of the product. It is recommended that the inverter is installed in a dry environment, protected from water. It is best to ensure sufficient ventilation around the product and adequate airflow.

Warning : Never install the device in a closed box! This device cannot be used in parallel!

Caution : Risk of damage to equipment!

If the product is installed in a box, ensure that there is sufficient ventilation inside and outside the box. An enclosed environment will cause excessive heat build-up and shorten its service life.

Please read all installation instructions carefully before starting the installation and follow the requirements strictly. Failure to do so may damage the product and affect its normal use.

A set of tools necessary for installation:

- Insulation stripper
- Wire cutter
- Phillips screwdriver
- Crimping machine
- Pneumatic drill
- Level
- Metal saw (for cutting pipes with protective conductors)
- Nails for the wall

CHOICE OF CABLE DIAMETER

Choosing the correct cable diameter is crucial to the proper operation of the inverter. To ensure optimum performance, ensure that the voltage drop on the cable from the inverter to the solar panel, from the inverter to the heater and from the inverter to the water dispenser is less than 2% of the system voltage.

On the basis of the calculated voltage drop and length of the conductors, select the appropriate conductor diameter according to the following table of minimum conductor diameter requirements at an ambient temperature of 45 degrees Celsius:

| | Maximum current | Cable type | Recommended cable diameter | Minimum conductor diameter required |
|----------------|------------------------|-------------------|-----------------------------------|--|
| Between | 20A | Copper | 6.0mm ² | 4.0mm ² |

| | | | | |
|--|-----|--------|--------------------|--------------------|
| inverter and photovoltaic panel | | | | |
| Between inverter and load | 20A | Copper | 6.0mm ² | 4.0mm ² |
| Between the controller and the AC input | 20A | Copper | 6.0mm ² | 4.0mm ² |

Remember that the right choice of cable will ensure long-lasting and trouble-free operation of the system.

HEAT CHOICE

Output interface: The heating load power must not exceed 230V/4000W and the resistance value must not be less than 13 ohms.

WALL MOUNTING

1. Choose the right set of mounting holes: Find the mounting holes that best suit your chosen wall location.
2. Mounting the unit :Mount the unit vertically on the wall using wall screws (dowels). Make sure that the inverter is fixed firmly to prevent it from falling.

Illustration 4

Note : Make sure the location is dry, well ventilated and can support the weight of the unit.

Ensure that the equipment is fixed vertically relative to the mounting surface. If the installation angle deviates from the vertical by more than 45 degrees, this may result in poor ventilation of the product, which may affect its performance.

Removal of wiring cover

Warning : Risk of electric shock!

Ensure the unit is disconnected from all power sources before removing the wiring cover. Leave the unit idle for at least 5 minutes to ensure that the residual energy inside the inverter has been discharged to a safe level. Any live operation poses a danger to the operator and may damage the product. Remove the cover as shown in the figure below.

Illustration 5

Figure: (Illustration showing how to properly remove the wiring cover)

CONNECTION OF POWER CABLE

Warning: Risk of electric shock!

The maximum open circuit voltage of the solar panel set should not exceed the maximum value of 420VDC specified by the inverter. Ensure that the solar panel and cable are disconnected before installation.

Steps to connect the wires:

1. Switch off all switches connected to the controller:
2. Ensure that all switches are in the OFF state.

Note : There is no built-in switch in the unit.

Connecting the solar panel cables

1. Connect the positive (+) lead of the solar panel to the PV+ terminal on the inverter.
2. Connect the negative (-) lead of the solar panel to the PV- terminal on the inverter.

Warning : The positive and negative poles of the solar panel must not be interchanged!

Connecting load lines (LOAD)

1. Connect the load lead to the OUTPUT terminal on the inverter.
2. Select a load with sufficient power. The power of the load must not exceed 230V/4000W and the resistance value must not be less than 13 ohms.
3. Connect the L wire of the load to OUTPUT L.
4. Connect the N wire of the load to OUTPUT N.
5. Connect the PE wire of the load to OUTPUT PE.

Warning : The product is designed exclusively for heating resistance heating elements by means of solar energy. The product load may only be connected to resistance heating devices with a heating power in the range 230V/4000W, such as electric water heaters, heating cables, heaters, PTC heating elements. Capacitive or inductive loads may damage the product.

Connecting the AC supply

1. Connect the AC mains line to the AC IN terminal on the inverter.
2. Connect the L wire of the AC mains to the AC IN L.
3. Connect the N wire of the AC mains to the AC IN N.
4. Connect the AC mains PE lead to the AC IN PE.

Warning : Make sure the earthing connection is correct!

Caution : Before carrying out any wiring work, ensure that the inverter is disconnected from all power sources to avoid the risk of electric shock and damage to the unit.

POWER ON

Attention : Pay attention to the terminal markings! Connecting the photovoltaic to the AC IN or AC OUT terminal, connecting the AC IN to the photovoltaic terminal or connecting the AC IN to the AC OUT will cause irreparable damage to the product.

Warning : make sure the polarity is correct! If the positive and negative poles of the solar cell set are connected in reverse, the controller will not function properly.

Warning : Before switching on the power supply, make sure that the earthing is correctly connected. Incorrect earthing will affect the current leakage protection function and may cause danger to the user!

Power-up procedure

1. Confirm the polarity of the solar cell set: Ensure that the positive (+) and negative (-) wires are correctly connected.
2. Check the condition of the earthing cable of the mains plug: Ensure that the earthing cable is in good condition.
3. Switch on the PV input switch: close the PV input switch. If the voltage from the solar panel is adequate, the controller will start to use solar energy for heating.
4. Switch on the AC input switch: close the AC input switch. If no voltage is available from the solar panel, the controller will switch to AC IN and AC OUT power.

Note : Following the above steps is crucial to ensure the safe and correct operation of the inverter !!!

POWER OFF

Warning : Pay attention to the power-off sequence!

To safely switch off the power, follow the steps below:

1. Disconnect AC power source: Make sure the product is disconnected from the mains. Turn off the AC input switch.
2. Disconnect solar panel: Make sure the product is disconnected from the solar panels. Switch off the PV input switch.
3. Check the connections: Ensure that both the AC power supply and the connection to the solar panels are completely disconnected from the inverter.
4. Removal of other wires: Once you have ensured that the product is completely disconnected from the AC power supply and solar panels, you can safely remove the remaining cables.

Note : The correct power-off sequence is crucial to ensure user safety and protect the product from damage.

PRODUCT HANDLING

Solar energy is the priority power source, and when solar energy is insufficient, the inverter will automatically switch to AC power.

Maximum power point tracking technology (MPPT)

Maximum Power Point Tracking (MPPT) technology detects the power generated by the solar panel in real time and tracks the maximum power generated by the solar panel to ensure that the solar cell array can operate at the current maximum power point. This process is carried out automatically by the DSP (Digital Signal Processor) through a series of calculations.

Setting the maximum water temperature

1. On the operating panel, press the "up" (up arrow) key.
2. The PV (solar water heating) temperature setting will be displayed.
3. Press the "enter" (OK) key.
4. The maximum water temperature setting number will start flashing.
5. Use the 'up' (up arrow) and 'down' (down arrow) keys to select the maximum PV temperature (you can choose between 55°C and 80°C).
6. Press the "enter" key again to complete the setting (the number will stop flashing), or press the "esc" key to cancel the setting.
7. When the PV is heated, the water temperature reaches the maximum temperature set for the PV and the PV stops heating. When the water temperature falls 3°C below the maximum temperature set for the PV, the PV stops heating.

Setting the maximum water temperature for AC (heating with air conditioning):

1. On the operating panel, press the "up" (up arrow) key.

2. The AC temperature setting will be displayed.
3. Press the 'enter' key.
4. The maximum water temperature setting number will start flashing.
5. Use the "up" (up arrow) and "down" (down arrow) keys to select the maximum AC temperature (you can choose between 30°C and 80°C).
6. Press the "enter" key again to complete the setting (the number will stop flashing), or press the "esc" key to cancel the setting.
7. When the AC is heated, the water temperature reaches the maximum temperature set for the AC and the AC stops heating. When the water temperature falls 3°C below the maximum temperature set for the AC, the AC stops heating.

Protective functions

1. Solar panel power too high

The maximum output current of the controller is limited by the rated value. When the output of the solar panels connected to the controller exceeds the rated maximum value, the maximum output of the unit will be limited to the rated value. In this case, the inverter may not operate at the maximum power point of the solar panels. The output of the solar panels will be reduced.

2. Shortening the input line of solar panels

When the input line of the solar panels is short-circuited, this is equivalent to no solar power being supplied. Once the short circuit is removed, the inverter will automatically resume normal operation.

3. Protection against overheating:

If the ventilation around the controller is insufficient, the temperature of the controller housing may be too high, exceeding the normal operating temperature range. In this case, the product will gradually reduce the photovoltaic output until the output stops. When the case temperature drops below the protective temperature, the controller will automatically restore the output.

ALARMS

1. AC high input voltage alarm

Condition: If the AC input voltage exceeds 260VAC.

Indicator: The fault indicator (Fault) will light up.

Response: AC output will be cut off.

Recovery: When the voltage drops below 260VAC, the fault indicator goes out and the controller resumes normal operation.

2. PV high input voltage alarm

Condition: If the open circuit voltage of the solar cells connected to the controller exceeds the maximum input voltage specified by the device.

Risks: The product may stop working or become damaged.

Prevention: ensure that the open circuit voltage of the solar cells is below the maximum value specified by the controller to avoid damage.

Note : These alarms are designed to protect the controller from operating outside safe voltage ranges, preventing damage and ensuring reliable operation.

Inspection and maintenance

To prolong the life of the unit, carry out the following inspections twice a year.

1. System control

Check: That the controller is fixed correctly and that the environment is sufficiently clean.

Ventilation: Make sure there is good ventilation around the controller and clean the surface of the controller of dust and dirt.

Power cord: Check that the external power supply cable is not damaged due to ageing, friction, insects or small animals. Check the insulation. If the cable is damaged, replace it in time.

Loose wires: Check that the external power cable is loose and tighten loose wires.

LED indicators: Check that the LED indicators are consistent with the operation of the unit. If you notice any faults or erroneous indications, take corrective action immediately.

Earthing: Check that all earthing wires in the system are correctly earthed.

2. Controller wiring cover inspection

Caution : Risk of electric shock!

Ensure that all power sources connected to the controller are disconnected before removing the wiring cover. If the power has not been disconnected,

do not open the controller wiring cover. Do not open the controller wiring cover until 5 minutes after the power has been disconnected.

Check: That the power cable in the connection box is not damaged due to ageing, friction, insects or small animals. If there is any damage, repair or replace it in time.

Loose wires: Check that the power cable in the junction box is loose and tighten loose wires.

Problem solving

1. no LED indicator, controller appears to have no electrical connection and does not switch on.

Solution:

- a) Use a multimeter to measure the voltage at the terminals of the controller's photovoltaic panel. The voltage at the terminals of the photovoltaic panel must be above DC 160V for the controller to operate. If the voltage at the terminals of the controller's photovoltaic panel is between DC 160V and 350V and the LED indicator is not lit, contact your installer.
- b) Use a multimeter to measure the voltage between the AC L-N socket and the AC voltage range. The voltage must be above AC 180V. If the voltage between the AC L-N socket is between AC 180V and 260V, check that the AC plug is correctly inserted or well connected. If the LED indicator does not light up, contact your installer.
- c) If voltage has not been measured at both ends of the controller's photovoltaic panel wiring terminals, check that the photovoltaic cable is in good condition and that there is a fuse or circuit breaker on the circuit. If there is no voltage at the AC socket, check that the AC supply is normal.

2. the red alarm light is on

Solution:

- a) Check that the controller has triggered the protection state described in section or the failure state described in section.

Warranty service regulations and repair process

1. Warranty service regulations

Within two years from the date of manufacture, any malfunctions related to the operation of the product that are not man-made can be covered by the warranty service.

2. Warranty exceptions

The following situations are not covered by the warranty service:

- Man-made damage such as accidents, negligence, improper installation or misuse.
- Damage caused by solar cell voltage, power or load current exceeding nominal values.
- Damage to the controller caused by selecting heaters with excessive specifications.
- Modifications or repairs to the product without authorisation.
- Damage caused during transport.
- Damage caused by natural disasters such as lightning and extreme weather.
- Damage caused by factors such as fires and floods.

Attachment 1

1

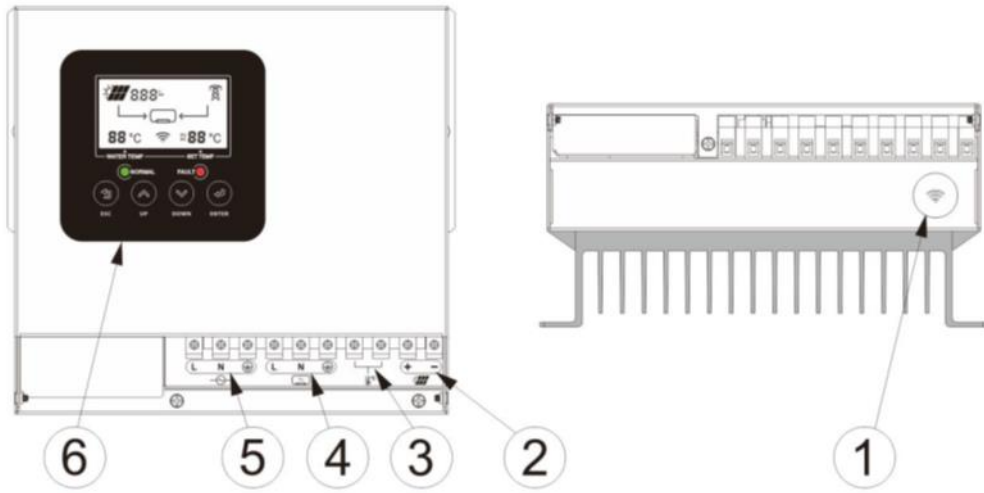

2

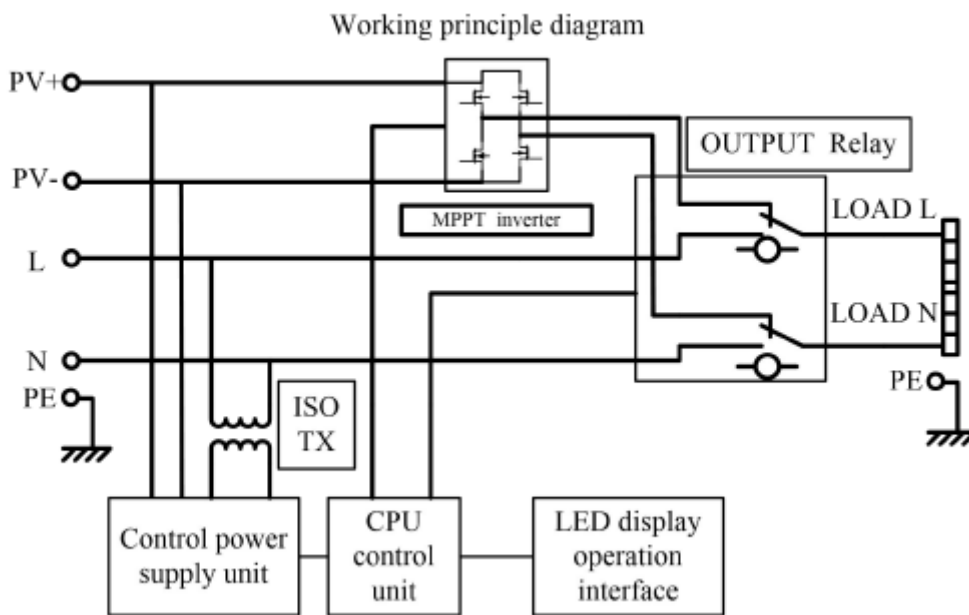

3

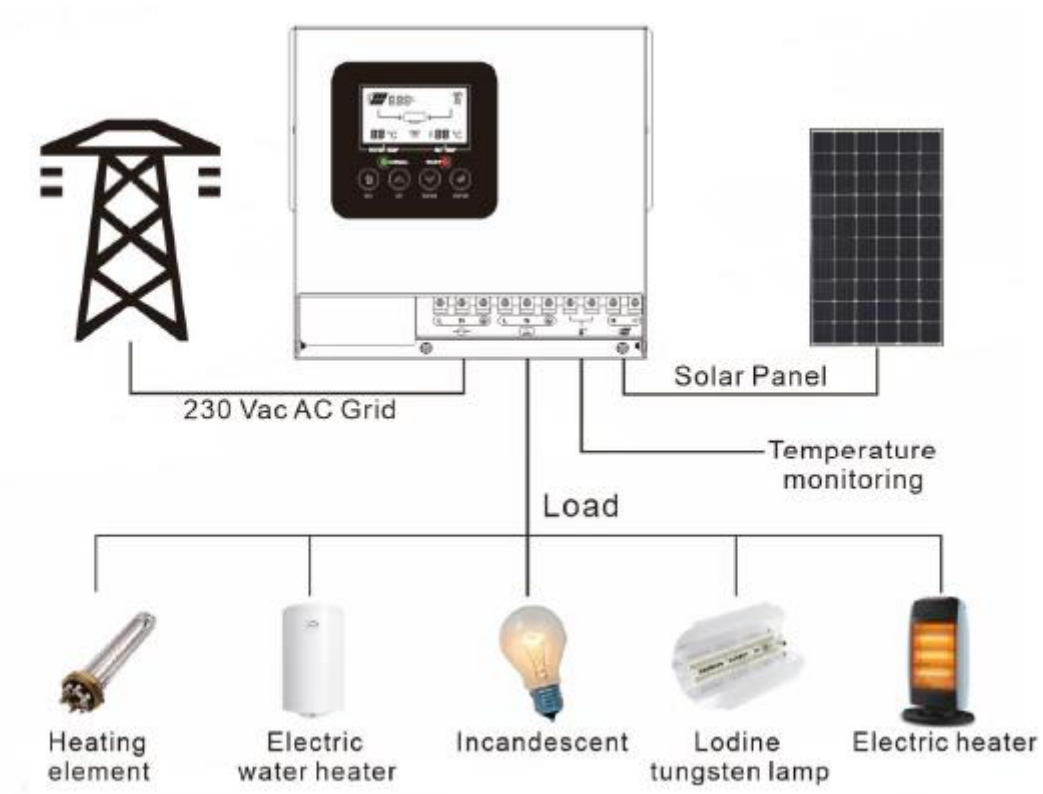

4

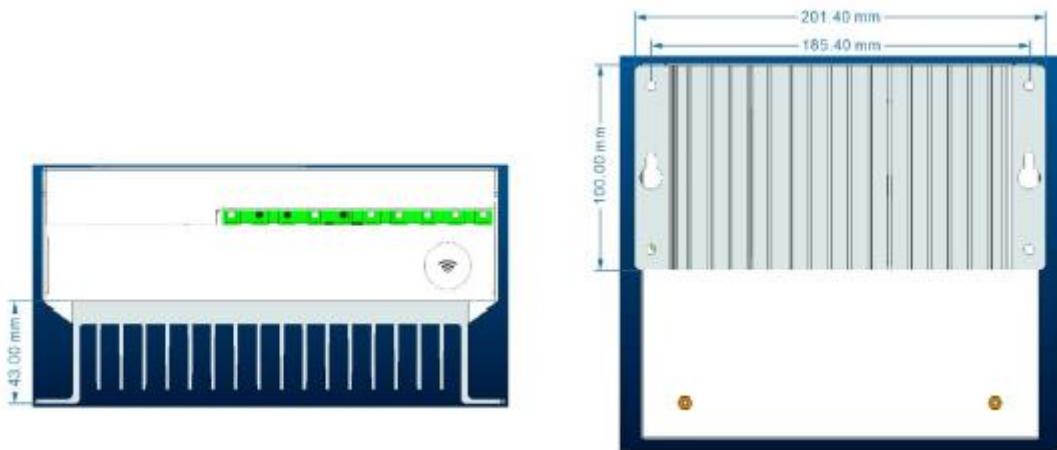

5

